



CONNECTED IN QUALITY.

ASTM F1387 – Mechanically Attached Fittings (MAFs)

2023 Update

by Jesus I. Herrero, Viega LLC

History of Welding and Brazing

There are 100 years' worth of paperwork justifying welding/brazing as the ideal method for shipbuilding.

- In 1920, the first all welded hull was launched, HMS Fullagar.
- However, welding is the most expensive and time-consuming component of the shipbuilding manufacturing process.
- Navy loses one ship to fire every seven years on average. 600+ Ship fires documented in three (3) years –Greater than 50% were attributed to hot work.
- Every measure to mitigate hot work on board should be contemplated. That is what we are here to talk about today. One of those technologies comes in the form of pipe joining with Viega MegaPress family of products, in this case MegaPress CuNi.

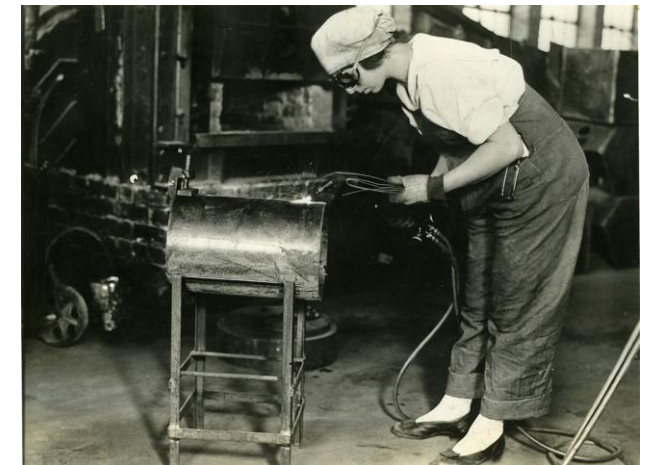

History of Viega MegaPress Systems

- The press-connect joining method (sometimes called press-fit) was patented in Europe in the late 1950s. This is an interference fit. It forms the basis for MegaPress connection systems.
- Press technology incorporates a pressed (crimped) connection to form a mechanical attachment to pipe and an elastomeric sealing element to seal whatever fluid is inside (or outside) from leaking. It is governed by ASTM F3226.
- 22M+ MegaPress fittings sold
- 2,500+ Applications



NSRP Project History

- 2018 – funding for first set of tests, Shock and evaluation of other tests necessary to qualify the system to the higher ASTM F1387 Standard.
- 2020 – funding for second set of tests
 - March 2021 NAVSEA Letter for ½" ProPress coupling
 - May 2021 NAVSEA Letter for MegaPress CuNi ½" thru 2" couplings
 - Cost Comparison (MegaPress CuNi vs CuNi socket weld) – 53%
 - April 2022 NAVSEA Letter for MegaPress CuNi Couplings, Elbows (90s & 45s), TEEs
- 2022 – funding for NAVSEA specific Train the Trainer program development and training
 - 11 participants from 2 shipyards and SUPSHIP-BATH were qualified as trainers.



ASTM F1387 Testing - MAFs

Intrinsic Fire Risk Mitigation, Reduced Installation Costs, Improved First Time Quality

Team: Wendy Greenbaum-BIW | Mike Poslusny-Gibbs and Cox | **Jesus Herrero-Viega LLC** | Willard Calvert-NAVSEA | Erin Babik – NAVSEA | Thomas Brodrick - NAVSEA]

Mechanically Attached Pipe Fittings Require Qualification VIA ASTM F1387

Mechanically attached pipe fittings are a less expensive fabrication method for pipe assembly and can reduce risk associated with fire due to welding

NSRP Project Performs ASTM F1387 Testing

This includes testing a lead-free fitting for potential use in Potable Water Systems and improving/refining ASTM F1387 to make it easier for vendors to qualify fittings.



Project ROI

56% Cost reduction in initial installed cost calculated by NAVSEA 05C.
More than 100% ROI on installations when considered reduced testing costs due to near zero leaks and concluding testing in one round according to NASSCO study.

Project Benefits

1. Two NAVSEA Letters issued (MegaPress CuNi and ProPress (copper))
2. Better methods for shock testing.
3. Fittings did not originally pass shock test but a minor change to tooling has allowed fittings to pass..



#

Two (2) systems approved
MegaPress CuNi
(1/2" thru 2"
ProPress (copper)
lead free alternative

#

NAVSEA 05C Cost Comparison indicates 56% reduced initial installation cost

#

19 systems (MegaPress CuNi)
4 systems (ProPress)



Current Standing

- We have made great progress since April of 2022 (NAVSEA letter):
 - Currently specified on several systems on FFG program
 - Approved on DDG – already on DDG(122)

The BIW pipe fitters implemented the training from the class on DDG 122. They were extremely happy with the results. They needed to do a pipe repair in a space that had already had its Government Inspection (GI) completed. At BIW, spaces are locked after GI. It was found that it took longer to get in the GI completed space, than it did to do the repair using the MegaPress CuNi fittings.
 - Scheduled for a Barge Shock Test in Q4 for XL Sizes and MegaPress 316
 - We have already trained the 1st group of Trainers along with SUPSHIP

Four spools were pressed, by the class participants, while experienced braizers built a single brazed assembly. The time trial was recorded on video.
... A third pipe spool was built during the class. This spool was pressurized to the maximum test pressure of the MegaPress CuNi fittings (600 psig) and then was distorted to show that even with unacceptable care of the fittings and spool the joints held, and the fitting was not distorted.

Torture Test – resides on NSRP YouTube channel

<https://www.youtube.com/watch?v=VqTFb75XZRQ>

Approved Configurations

- Couplings $\frac{1}{2}$ " thru 2"
- 45 elbow
- 90 elbow
- Reducer Couplings
- TEEs
- Reducing TEEs

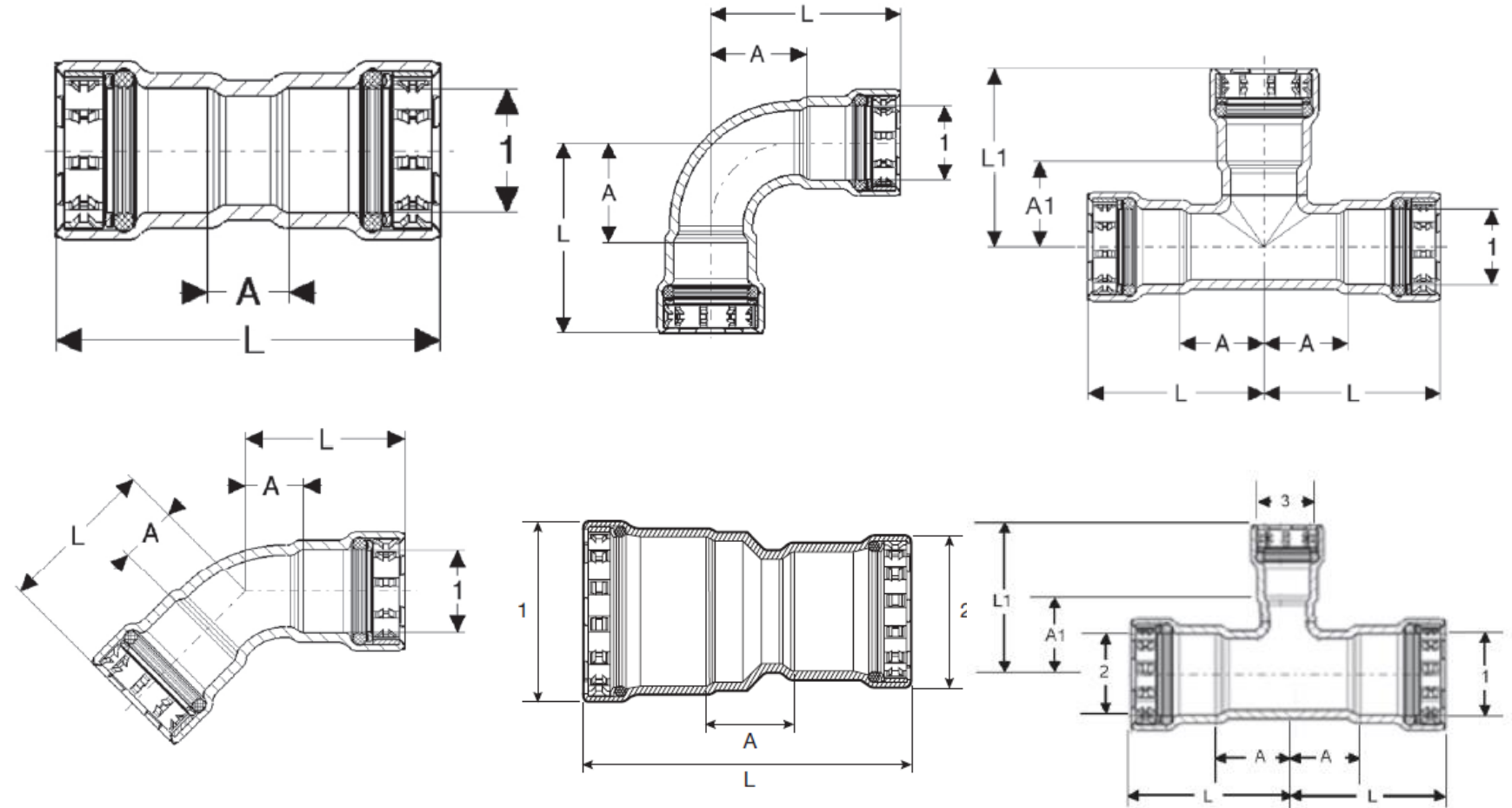

Configurations (Pending Shock Extensions)

- No stop Couplings
- Flanges 1" up
- Adapters 1/2" thru 2" (MPT/FPT)
- Threaded reducing tees FPT
- Street Fittings
- XL sizes 2-1/2" thru 4"

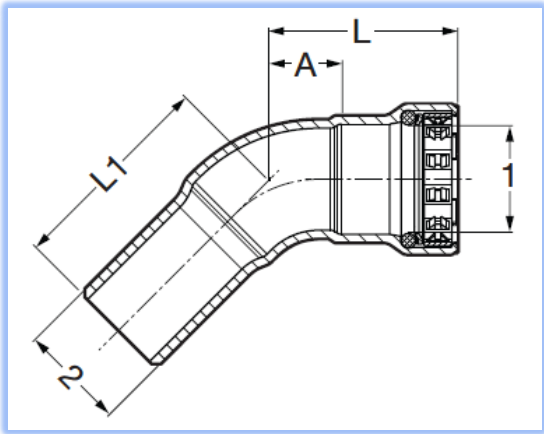
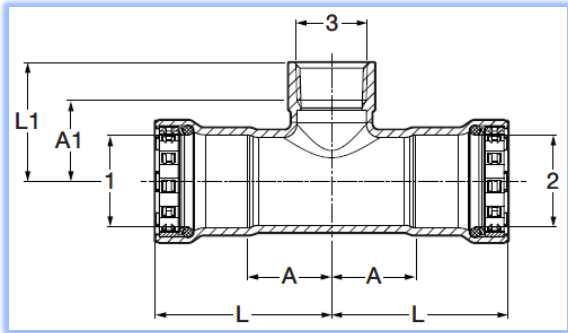
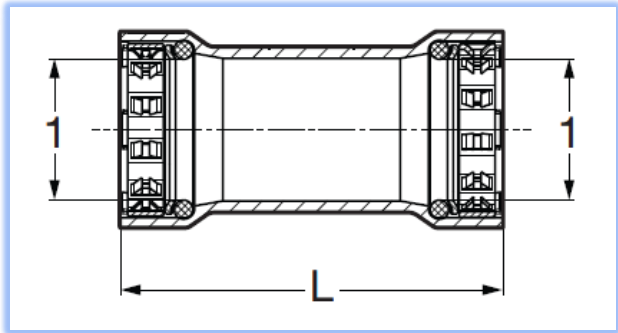
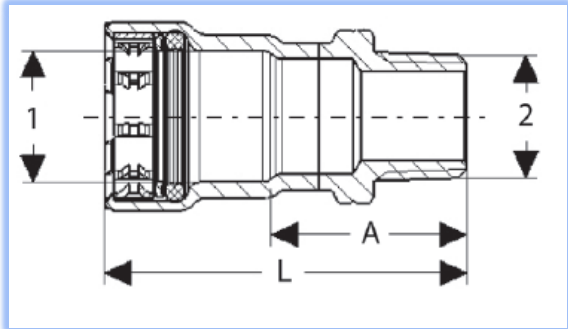
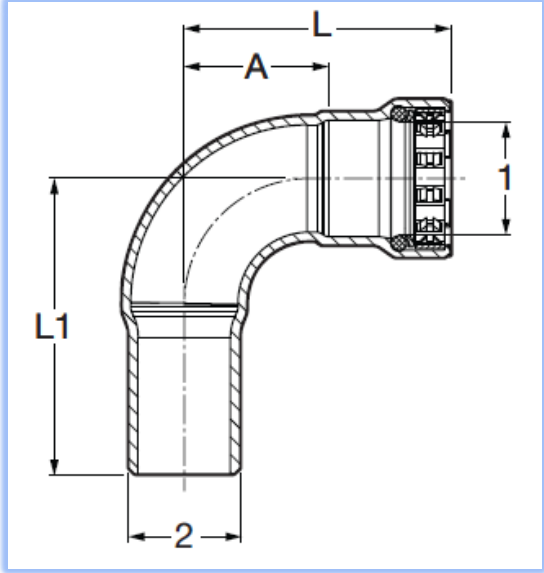
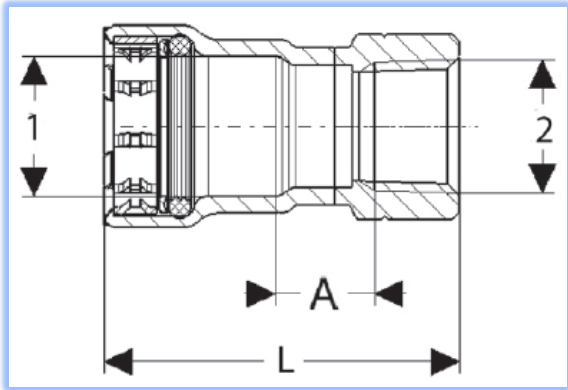
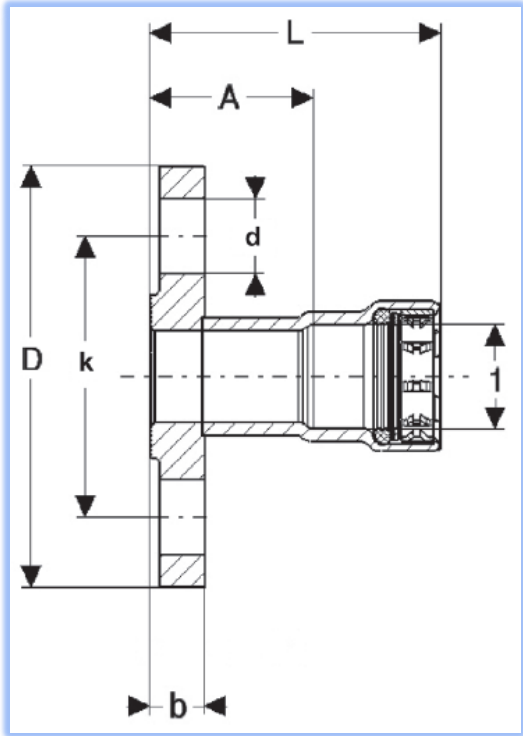

RAP: Implementation of Press Connect Fittings (Train the Trainer)

- Prime/Lead: GD-Bath Iron Works
 - Team members:
 - GD Bath Iron Works
 - Fincantieri Marinette Marine
 - SUPSHIP-BATH
 - Viega LLC
 - 3 Days
 - 7 Assemblies
 - Lots of fun and learning

| NSRP Pilot Training Program - May 9-11, 2023 | |
|---|---|
| Registrant Name | Title/Function |
| GD Bath Iron Works attendees | |
| Wendy Greenbaum | Principal Engineer/Planner |
| John Skillin | Trade Training Specialist |
| Amy Hubmann | Pipe Fitter Trainer |
| Matthew O'Brien | Tradesperson/Installer |
| Fincantieri Marinette Marine attendees | |
| Luis Woll | Department Manager/Team Lead |
| Nicholas Duer | Department Manager/Team Lead |
| Jordan Stumbris | Foreman |
| Matthew Lewis | Instructor - Northeast Wisconsin Technical College |
| Aaron Staskiewicz | Trades Instructor - Northeast Wisconsin Technical College |
| Supervisor of Shipbuilding attendees | |
| Gary Morissette | Supervisor of Ship Building , Bath |
| Joseph Leeman | Supervisor of Shipbuilding, Bath |

RAP: Implementation of Press Connect Fittings



NSRP SDMT 2023 – ASTM F1387 – Mechanically Attached Fittings (MAFs) – 2023 Update

July 13, 2023

Final Assembly

The Final Assembly consisted of:

- 16 connections
 - 8 ea 2"
 - 2 ea 1-1/4"
 - 6 ea 3/4"
- Cap and Valve are not CuNi but were included to ease testing (they have been replaced with threaded adapters for subsequent lessons)
- Two person teams set to the task

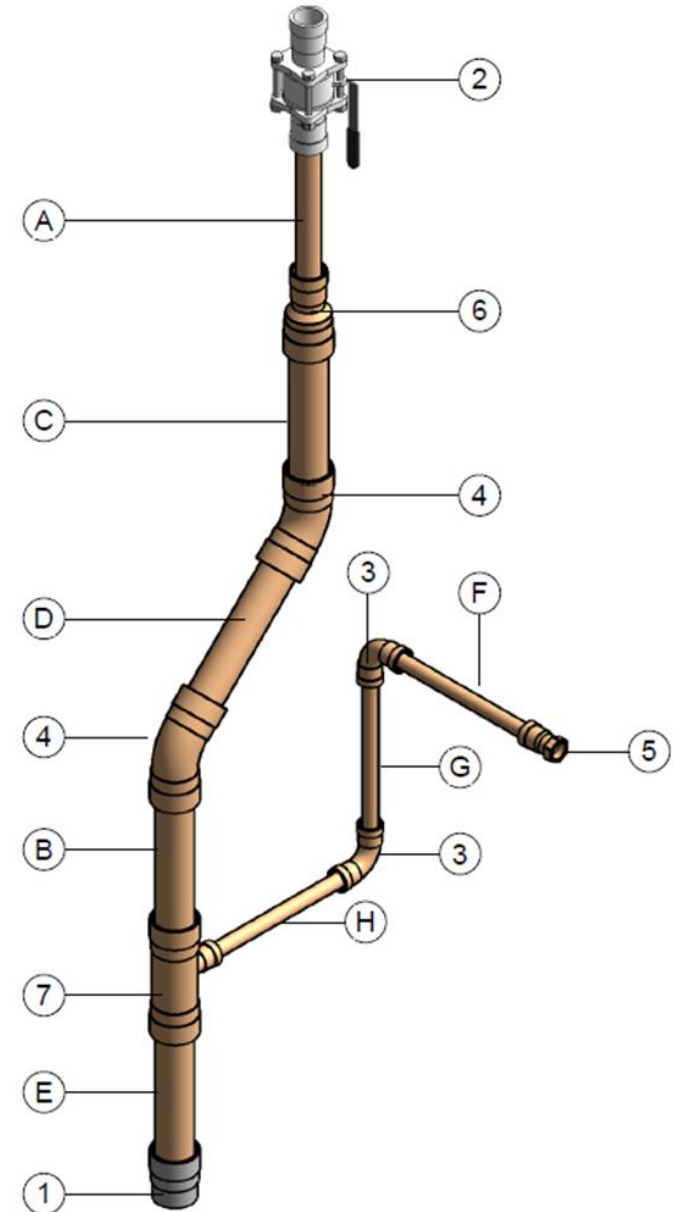

Let's see how it worked out

Insert Teams Video Here

How does Silver-brazed work out against MegaPress CuNi



Bronze Silver-Brazed vs MegaPress CuNi

Insert Side-by-Side Video Here

Streamlined Construction, Higher Quality

MegaPress CuNi

PREP – 3:00 min

Build Complete – 15:26 min



Clean – no flushing required
(MAF)

Commission on 1st Round

Bronze Silver Brazed

PREP – 20:00 min

Build Complete – 2:05:17 (125 min)



Tarnish and Flux - Cleaning and
Flushing required

An average pipe welder produces
5% to 30% bad welds

MegaPress Systems deliver Fast Consistent Connections

MegaPress CuNi

- No Hot Work, No Chemist
- Fast (15:26/125:17 Greater than 8X efficiency)
- Commission on 1st Round (Near zero failures)
- Lead Free
- Improve delivery schedule
- Improve your bottom line

Bronze Silver Brazed

- Firewatch (RISK & Labor)
- Inert Gas (RISK & Labor) – chemist & ventilation to prevent suffocation at the bottom of the ship
- Typical 5%-30% Failures
- Multiple round commissioning
- Delays