Composite Components for Reduced Maintenance and Total Ownership Cost

**Dr. Maureen Foley
Naval Surface Warfare Center
Carderock Division**

NSRP 2023

Examples of Corroded Components

MIL-PRF-24758A Connector*



Stowage Box!



Sound Powered
Phone Jack Box*



Deck Drain*



LHD well deck
grating *



Vent Screen*



Sunshields for Ready Service Lockers*

* Composite version available †Composite version in development



Methodology for New Component Development



1. Identification of Target Components

- Input from maintenance personnel, ships' forces, port engineers, Corrosion Control Assistance Teams (CCATs) and program offices used to identify specific components which require frequent maintenance.

2. Requirements Definition

- Analysis to determine the current requirements of the component.
- Interactions with cognizant Technical Warrant Holders (TWHs).

3. Prototype Fabrication, Evaluation and Demonstration

- Prototype of composite components fabricated under the Painting Center of Excellence (PCoE) Program and evaluated per the requirements defined during the Requirements Definition Phase.
- Prototype iterated as necessary and Ship Change Document (SCD) generated to allow for fleet demonstrations.

4. Trial Inspection and Institutionalization

- Inspections performed of the fielded component dependent on ship availability.
- Installations documented and ships' forces queried for feedback on success of installation and any lessons learned documented.
- SCD's, Deviation from specification, (DFS), NAVSEA Drawing packages, and National Stock Numbers (NSN) established as part of the institutionalization process depending on the component. Transition path determined through interactions with program office and stakeholders.

History of Composite Component Development



Composite Component Technical Manual

➤ **Draft Composite Component Technical Manual In Process**

- Published initially as a NSWCCD Technical Report that will be converted into NAVSEA publication posted on TDMIS

➤ **For each component it will provide the following information:**

- Background
- Technological Advantages
- Applicable Drawings/Documentation
- Procurement Information
- Installation Guidelines
- Allowance Parts Lists with Repair/Replacement Parts
- Planned Maintenance System Information (MIP/MRC)

Fleet Transition Paths

- **Transition of Composite Components is complicated as it can be performed at many levels**
 - O-Level
 - NSN, APL, COSAL, CD-MDOA, PMS, etc.
 - I-Level
 - SCD / AER
 - D-Level
 - Class Standard Work Templates, Design Memos
- **Each level requires its own set of paperwork and documentation for the transition to take at that level which makes the transition difficult.**
- **Need feedback from each level if additional documentation is needed.**

DDG51 Class Overboard Discharge Scuppers (Demo)

- Polymer 3D printed overboard discharge scuppers to eliminate running rust.
- Demonstrations occurring in FY23.
- Models available for several different sizes and types of scuppers.
- Can be printed at local RMC AM facility and then attached to the hull using simple attachment methods such as sealant and double sided tapes.
 - FY23 demonstrations will use several different methods to determine best path forward.
- Several RMCs have been provided files for demonstration to support ship checks to evaluate design prior to transition
- Flexible Thermoplastic Urethane (TPU) version more impact damage tolerant than the ABS version.

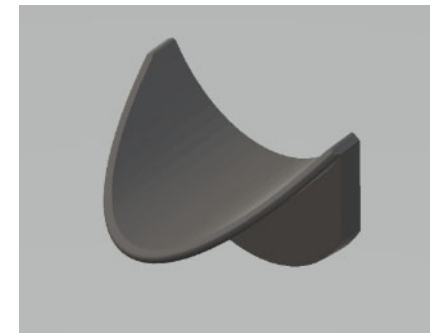

Designed to break away and be easily replaced with new one without hot work.

Scupper Selection Process (Demo)

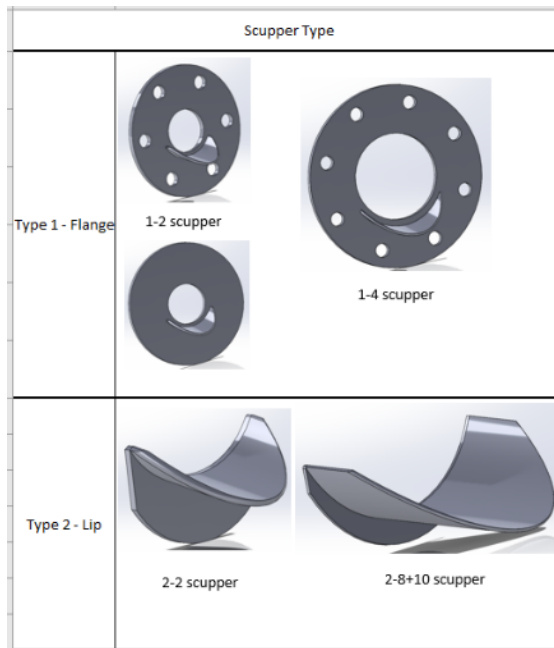

Attachment

- Remove legacy drain lip
- Surface preservation
- Attach scupper to hull with tape/sealant

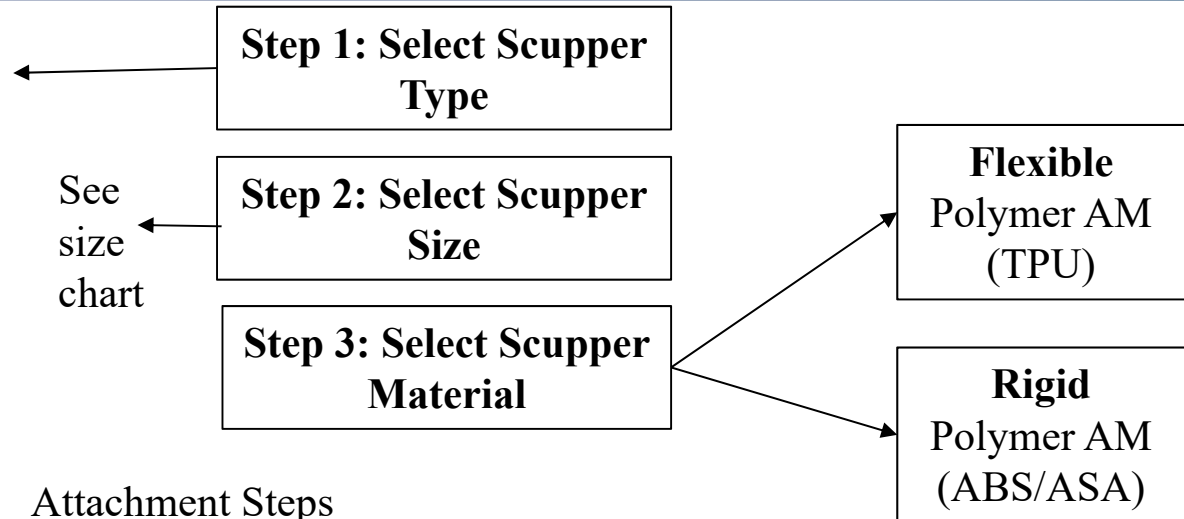

Attachment Steps

1. Use FSR to clean surface
 - If rust present, recoat area using standard techniques.
2. Prep scupper with 3M Primer 94. (90 second dry)
3. Attach 3M VHB 5962 tape to scupper. Use roller to iron out any entrapped air and trim to scupper shape.
4. Prep painted hull surface with 3M Primer 94
5. Align scupper a couple of inches from hull with the outlet pipe opening. It is very important to align properly as the tape is not easily removed.
6. Press scupper evenly onto hull for several seconds.
7. Use Masterweld 622 sealant to place a bead around bonded area.

Scupper Size Chart (Demo)

For each Scupper need to select, Type, Size and Material (Rigid or Flexible)

Overboard Discharge Pipe Size	Type 1 Scupper Part Number	Type 2 Scupper Part Number	Type 1&2		Type 1
			Inner Flange Diameter (in)	Max Lip Depth (in)	Outer Flange Diameter (in)
2 NPS	1-2	2-2	2.125	2.25	6.5
3 NPS	1-3	2-3	3.25	2.75	8
4 NPS	1-4A	-	4.25	3	8
4 NPS	1-4	2-4	4.25	3	9
5 NPS	1-5	2-5	5.25	3.5	10
6 NPS	1-6	2-6	6.25	4	11
8 NPS	-	2-8	8.25	4 5/8	-
10 NPS		2-10	10.25	4.75	-

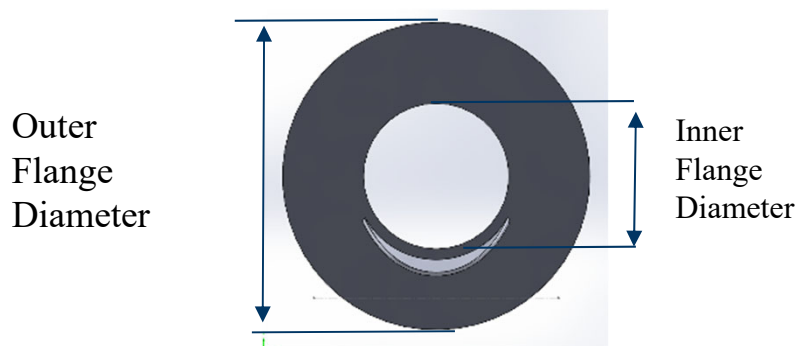

Baseline version of Type 1 will be without holes

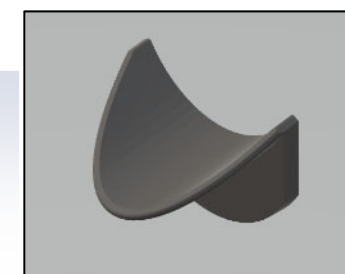
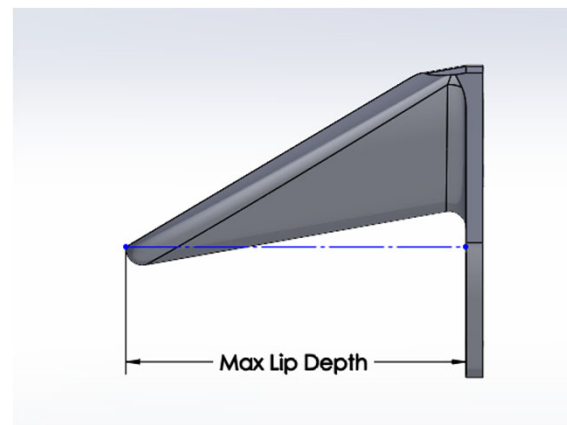

Type 2

DDG 51 Class Anti-Siphon Guards (Demo)

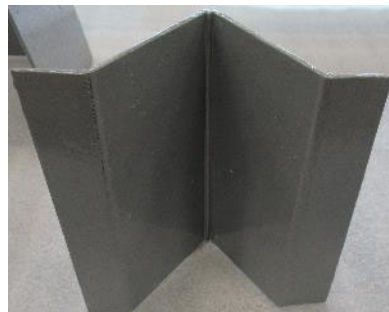
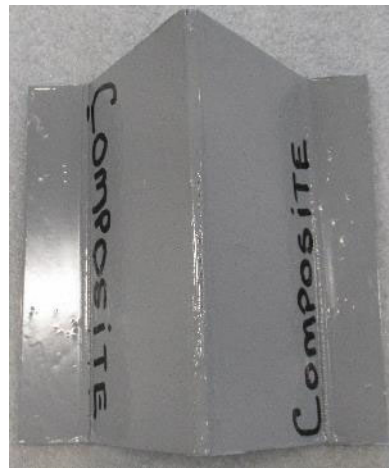

- Anti-siphon guards are used at many locations along the hull and bulkheads for smaller pipe egress.
- Basic sheet metal bended component welded to hull/bulkhead directly or with welded studs.
- Potential to eliminate studs and use same proposed method for scupper attachment.
- Prototypes being developed for demonstration in FY23.

Corrosion-Resistant Cease Fire Alarm Horn (Transitioning)

➤ **NSWCCD was funded by PMS 505R to investigate the corrosion issues related with the cease fire alarm horn that is causing excessive failures.**

- Identified several installation issues that is contributing to failures.
 - Improper plug used in extra cable access hole. Need metallic plug installed.
 - Weep hole on cover/projector not installed closest to the deck to allow for water drainage.
 - Ground wire not always installed from component to connection point.
 - Corrosion prone hardware is installed for the noise making components as well as the projector/cover unit.
- Developed Corrosion Upgrade kit for the Cease Fire Alarm Horn that documents the form, fit and function replacement corrosion resistant parts to extend the life of the current horns.
 - Includes a polymer based 3D printed projector/cover combination that can be printed at any local RMC AM facility
 - NAVSEA TDP package approved
 - NSN application in process
 - Corrosion resistant hardware included in the general notes section of the technical data package (TDP) for the 3D parts.

Replacement Plug

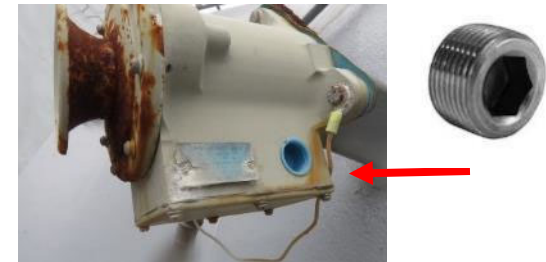

Replacement Hardware



3D printed and painted

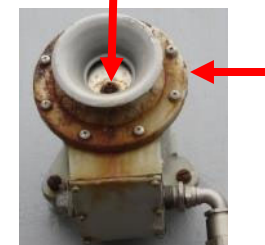

Flame Arrestor Protective Screen (Transitioning)

➤ Flame Arrestor Vent Screens

- NSWCCD has identified a commercial off-the-shelf (COTS) composite mesh screen material that can be used as a form, fit and function replacement for the outer protective screens in flame arrestors/air escapes.
- NSN available for 1-ft square pieces (5 qty)



LHD 3

DDG 79

USNA Waterfront Readiness Center

YP 703

YP 689

Composite Gauge Panels (Transitioning)

- **NSWCCD developed a single composite instrument gauge panel that can be a form, fit and function replacement for the configurations shown.**
 - Flush or surface mounted, 1 or 2 connections per side
 - Passed shock and vibration testing
- **Initial demonstrations of the technology started in FY21.**
 - Match drilled to shipboard configuration.
 - NSNs application in process will be added to the ship class Corrosion Control APL to enable ship's use.
- **NSWCCD providing equipment and some materials to allow MARMC to stand up composite gauge panel fabrication cells in FY23**
- **In FY23 developing a DDG 51 class trapezoidal configuration.**



CG 64



DDG 51 class
configuration



CG 64

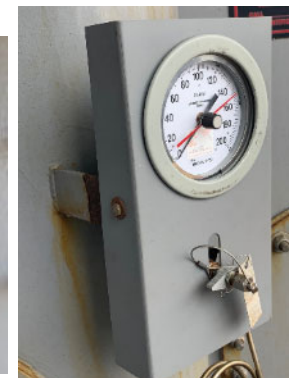

LSD 52

Composite Sunshields for Ready Service Lockers (RSLs) (Transitioning)

- Lockers are typically powder coated steel which require re-powder coating every 3 years. →
- Extensive testing led to the publication of NAVSEA Drawing 710-8817012 Sunshield Composite 50 CAL Ammunition Ready Service Locker to capture requirements of composite sunshield material. In addition composite sunshields have been added as an option in NAVSEA Drawing 804-1360106H Locker, Details.
- SURFMEPP developed design memo that is referenced in standard work template (DDG 51 & LPD17) for call out in future availabilities.
- ONR Mantech funded project to develop commercial supplier.



Rounded corners sunshield



.50 caliber ammunition locker sunshield set

Distribution A : Approved for Public Release



SRBOC Locker Side Panel 14

Composite Strainer Plates (Transitioning)

- NSWCCD had developed designs and demonstrated composite strainer plates on LPD, LHD and CG class ships.
- A NAVSEA drawing was published to capture the 5 different designs as well as specifications for a generic plate design for other configurations.
- NSNs established and added to Corrosion Control APLs; SURFMEPP Design Memo (LPD and LHD) in process for citation in new standard work templates for future maintenance availability planning.

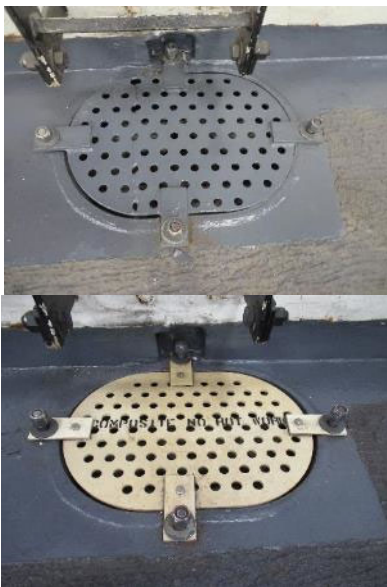

LPD 24 (7 months)



CG 72 (Nov 2020 Install)

Distribution A : Approved for Public Release

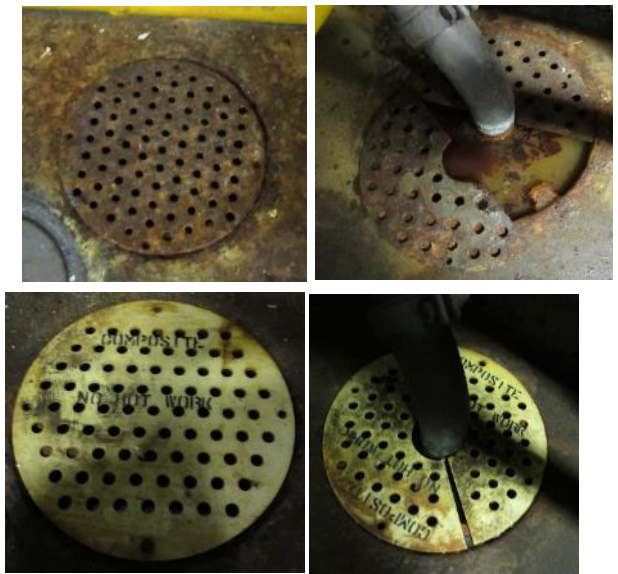

LHD 3 (5 months)

Composite Trough Cover Plates 03 Level and Bridge Wings



03 Level and Bridge Wing

- Port Engineer identified problem components.
- Prototype parts fabricated at NSWC Carderock.
- Glass fiber reinforced vinyl ester composite material coated with Formula 150 and MIL-PRF-24635 Polysiloxane, Deck gray.
- Matched drilled shipboard.
- NSNs Developed.
- NSNs added to Corrosion Control APL.
- Installation Video on Carderock YouTube site.
- SURFMEPP Design memo cited in DDG 51 Class Topside Corrosion Work Template.

Demonstration on USS Nitze (DDG 94)

DDG Only

Distribution A : Approved for Public Release

<https://www.youtube.com/playlist?list=PL7WRGH6pAuSfi0QGybiebcxe6jkRHUIbe>

Composite Electrical Enclosures



- NAVSEA DWG 803-6983506 Electrical Enclosure, Rev B.
- SCD 6922 All Surface Ships
- Replace when fail SCD 6922, up to ships to install, not currently planned into maintenance.
- FY22 topside replacement of 50 boxes, conduit and fittings on DDG 79.

LSD Well Deck Control Station

Logistics

- NSNs assigned for various enclosures and replacement parts.
- MRCs to note replacement parts that are available (flop lids & covers).

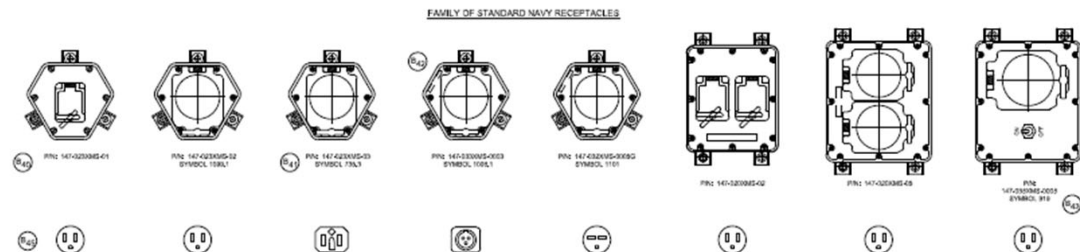
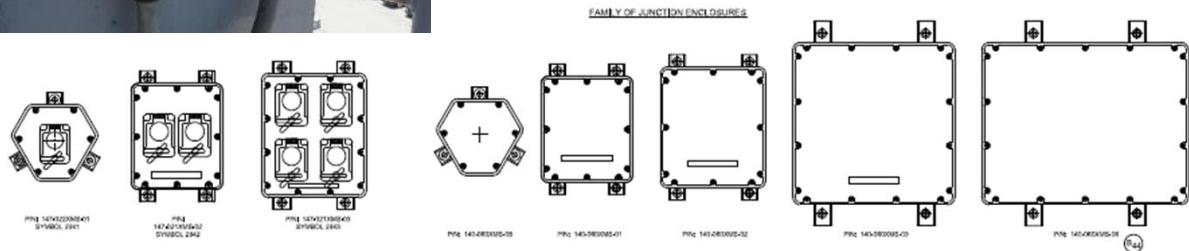

MIL-PRF-24758A Conduit Lightweight Corrosion Resistant End Fitting

- One of the three approved vendors for the MIL-PRF-24758A conduit systems has replaced the legacy stainless steel nut and sleeve on the end connectors with a composite material to come up with a lightweight, environmentally durable, lower cost, hybrid end connector.
- Lightweight fittings added to the Composite Electrical Enclosure APL (Allowance Parts List) that is currently associated with 108 ships. In process for adding the remaining ships under SCD 6922.

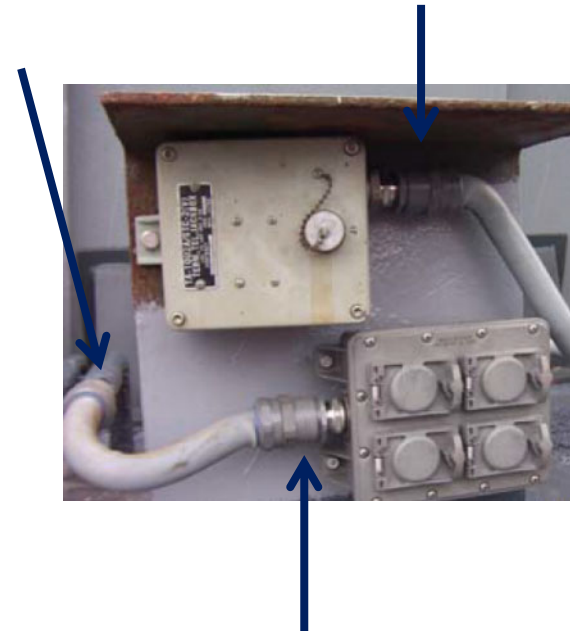

Adhesively Bonded Studs for Composite Electrical Boxes (DEMO)

- **NSWCCD has several demonstrations in process evaluating the use of adhesively bonded studs for the installation of composite electrical boxes.**
 - Demonstrations to support extension of the current approval for the use of a 1/4-20 stud in external topside locations (803-8436636 STUDS, ADHESIVELY MOUNTED)
 - Current approval only for internal applications
 - One welded stud must be maintain for the electrical ground path and in case of fire.
 - Cannot be installed in locations above six feet.

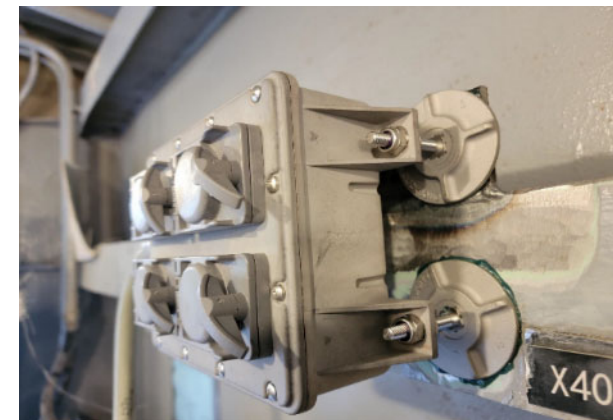

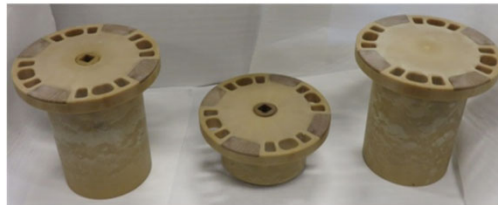

2 inch Type A 2 inch Type B 2 inch Type D
2 inch seal/trap 2 inch seal/trap

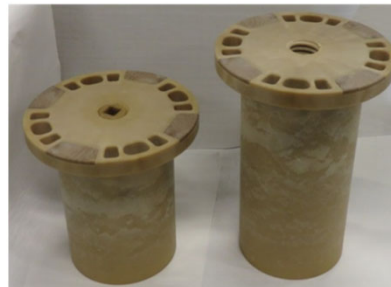

2 inch Type A 2 inch Type A
2 inch seal/trap 4 inch seal/trap



1.5 inch Type D 2 inch Type D
2 inch seal/trap 2 inch seal/trap



2 inch Type D 2 inch Type D
2 inch seal/trap 4 inch seal/trap



2 inch Type C

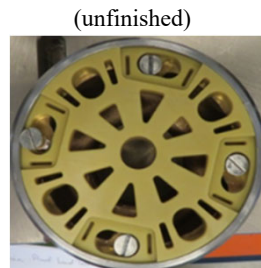

(unfinished)

Material

- 30% chopped glass reinforced Polyetherimide (PEI).
- NAVSEA DWG 803-6983511 Deck Drain Insert, Composite, 1.5 & 2.0 inch.

Logistics

- NSN for all configurations.
- NSN for shoulder bolts.
- Updated MRC's (A1JU and C4QV) and developed U-MRC J2NP for initial installation.
- Carderock YouTube Video for Installation Guidance and Deck Drain Size and Type Identification and hole repair.

<https://www.youtube.com/playlist?list=PL7WRGH6pAuSfi0QGybiebcxe6jkrHUIbe>

3D Printed Coamings for Composite Deck Drain Inserts

- In many cases, a vertical pipe emits fluid onto a deck drain fitting installed in a deck as shown below of a metal coaming to direct the flow into the drain.
- As composite deck drain inserts transitions to the fleet there is a need for similar technology.
- 3D printed coamings developed under Cross Platform (CPSD), System Development funding and now supported under PCoE funding. NSNs and Technical data packages, with installation guidance, for bonding to the composite deck drain inserts.
 - Local RMC AM facilities can print these components.

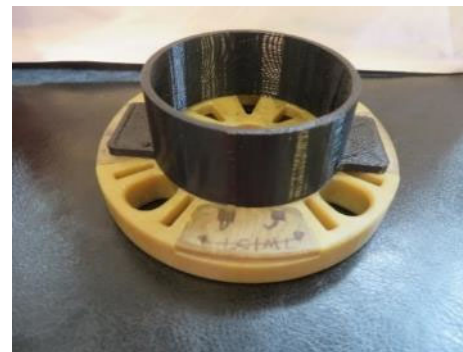

3D Printed Deck Drains (Demonstration)

- NSWCCD is exploring the possibility of expanding the family of non-metallic deck drains under funding by NAVSEA 05T.
- Deck Drains fall under the “Blue Box” category of polymer additive manufacturing (AM) parts that require additional qualification testing due to critical nature of component.
- 3D printed designs available for the 1.5 inch Type C and 2.0 Type A (CVN version) for demonstration.
- In process of qualifying components, Type A deck drain fitting passed shock test in FY22.



1.5 inch Type C

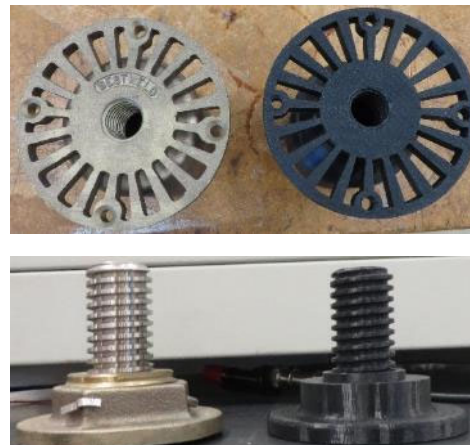

2 inch Type A

Composite Vent Screens



- Will not corrode like the legacy steel vent screen.
- Widely installed across the fleet on CVNs, L-ships and DDG classes.

Material

- Modified Acrylic (MODAR) based composite material.
- NAVSEA DWG 803-6983500 Vent Screen, GRP, Installation and Details.

Logistics

- NSN for Screen and M-Clip.
- MRC (Maintenance Reading Card) K2CB published (FY21) to establish inspection, cleaning and recoating procedures. Includes NSNs for replacement parts.

Updates

- New MRC cleaning and coating procedures.

Composite Deck Grating

Installed Composite Deck Grating



LSD Wing Wall



CVN Catwalk

Benefits

- 45% reduction by weight on CVN class catwalk (14 ton reduction).
- Will not corrode like the legacy steel grating.

Distribution A : Approved for Public Release

Material

- Phenolic resin based composite material.
- NAVSEA 803-6983499A, Deck Grating, GRP Installation and Details.

Logistics

- NSN for M-clip.
- NSNs for grating panel.
 - 3ft x 20ft, 4ft x 12ft, and 4ft x 6ft sizes.

Updates

- LCS1V SCD in process to replace legacy molded grating with this qualified material.
- Grating, Antenna platform, Glass Reinforced Plastic, NAVSEA drawing 804-4477915 revised in 2020 to call out this grating.

MIL-PRF-32664 Composite False Deck Panels (High Maintenance Application) (Transitioning)

- NSWCCD spearheaded the development and publication of MIL-PRF-32664, Performance Specification Deck Panels, False, Composite to capture the requirements for the panels used in raised floor installation on Navy ships.
- ONR Manufacturing Technology Composites Manufacturing Technology Center worked closely with NSWCCD to develop new false deck panel configurations that met the performance specification with 2 approved vendors.
- A design memo published by SURFMEPP for the development of a new standard work template to allow ships to request this new more durable product which requires significantly less labor to install than the legacy “nomex” panels.
- New panels have a resistant dielectric layer which improves wear and impact resistance.



Impact Test Results



Legacy-Nomex Core



Vendor 1-Aluminum Core



Vendor 2-Balsa Core 25

Composite Stowage Boxes and Drip Pans (In Development)



**USS Bulkeley (DDG 84)
(9 year demonstration)
July 2022**



**USS Nitze (DDG 94)
(almost 9 years installation)
(107 months-Feb 2020 ship
check)**



**Prototype Composite
Bilge Sump Cover Box
fabricated in NSWCCD
Composites Lab.**

Summary

- Looking to develop a composite box project to leverage previous demonstrations.
- Boxes can be used to make drip pans, stowage boxes or even bilge sump cover boxes.
- There is a wide range of applicability for materials that will not corrode and degrade like the current metallic components.

Summary

- **Composite based components have been developed to reduce the required maintenance due to corrosion.**
- **A standard methodology has been established to take new ideas from the fleet through the development process.**
- **Institutionalization for new components is developed through interactions with TWHs, In-Service Engineering Agents (ISEA), fleet, Readiness Managers and program offices.**
- **It is imperative that all logistics development, APLs, Coordinated Ship Allowance List (COSAL), NSN, Planned Maintenance System (PMS), occurs during development to ensure a smooth transition to the fleet.**

Acknowledgements

- **The majority of this work has been funded by PM Brittany Preston-Baker in NAVSEA 05PB under the Painting Center of Excellence (PCoE) program since FY19, and previous years under SEA 21, PMS 443 funding (SMARTWORK- Capital Investment for Labor).**
- **Office of Naval Research Manufacturing Technology funding for several projects were funded by PM Neil Graf under the Composite Manufacturing Technology Center.**
- **The Cross Platform Development Program and 05T for funding for the development of the 3D printed items.**



NSWCCD

Contact Information



Dr. Maureen Foley
maureen.e.foley4.civ@us.navy.mil
Cell (240)-383-8451